

Exercise 1: Linear Algebra Basics + Estimator Example
(to be returned on November 18th, 9 a.m)

Prof. Dr. Moritz Diehl, Katrin Baumgärtner, Naya Baslan, Jakob Harzer, Doga Can Öner

In this exercise you get to know some matrix properties. In addition, you investigate some important facts from statistics in numerical experiments.

Note: Please hand in the MATLAB tasks through Grader (<http://grader.mathworks.com>).

Exercise Tasks

1. ON PAPER: Consider the following linear system :

$$\begin{cases} a + b + 5c = 15 \\ 2a + b + c = 10 \\ 2b + 3c = -50 \end{cases}$$

Please bring it to the form $\Phi\theta = y$, where $\theta = [a, b, c]^T$

- (a) Specify the matrix Φ and the vector y , and give their dimensions.
(b) Compute the rank of Φ . Is it invertible? What does this mean for the solution $\theta = \Phi^{-1}y$?
(c) What other properties does Φ have, i.e. is it symmetric, orthogonal, positive semi definite, positive definite, negative semi definite, negative definite? (2 points)

2. ON PAPER: Consider the function $f(x) : \mathbb{R}^2 \mapsto \mathbb{R}^2$ with $x = [x_1, x_2]^T \in \mathbb{R}^2$

$$f(x) = \begin{bmatrix} 5 \log(x_1) - x_2^2 \\ 2x_1 + e^{3x_2} \end{bmatrix}$$

and its Jacobian matrix $J \in \mathbb{R}^{2 \times 2}$, defined as

$$J(x) = \frac{\partial f}{\partial x}(x) = \begin{bmatrix} \frac{\partial f}{\partial x_1}(x) & \frac{\partial f}{\partial x_2}(x) \\ \frac{\partial f_2}{\partial x_1}(x) & \frac{\partial f_2}{\partial x_2}(x) \end{bmatrix}.$$

Given the point $\bar{x} = [1, 2]^T$, is $J(\bar{x})$ invertible? (2 points)

3. ON PAPER: Show that for any $A \in \mathbb{R}^{n \times m}$ holds that $A^T A$ is symmetric and PSD.
(Hint: matrix B is PSD, if for any $x \in \mathbb{R}^n$ holds that $x^T B x \geq 0$).

(2 points)

4. (MATLAB). We consider the following experimental setup:

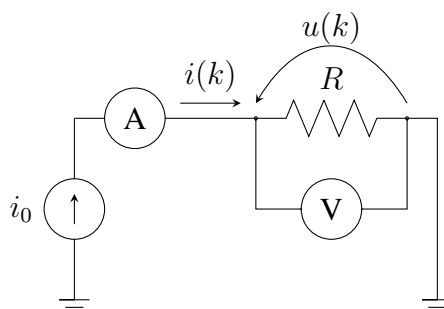

Imagine you are sitting in a class of 200 electrical engineering students and you want to estimate the value of R using Ohm's law. Since the value of the current i_0 flowing through the resistor is not known exactly, an ammeter is used to measure the current $i(k)$ and a voltmeter to measure $u(k)$. Every student is taking 1000 measurements. The measurement number is represented by k . We assume that the measurements are noisy:

$$i(k) = i_0 + n_i(k) \quad \text{and} \quad u(k) = u_0 + n_u(k)$$

where $u_0 = 10 \text{ V}$ is the true values of the voltage across the resistor, $i_0 = 5 \text{ A}$ is the true value of the current flowing through the resistor and $n_i(k)$ and $n_u(k)$ are the values of the noise.

Please consider the data-set with all measurements of all students provided on the course website (the same dataset is also available in Grader).

Let us now investigate the behaviour of the three different estimators which were introduced in the lecture:

$$\hat{R}_{\text{SA}}(N) = \frac{1}{N} \sum_{k=1}^N \frac{u(k)}{i(k)} \quad \hat{R}_{\text{LS}}(N) = \frac{\frac{1}{N} \sum_{k=1}^N u(k)i(k)}{\frac{1}{N} \sum_{k=1}^N i(k)^2} \quad \hat{R}_{\text{EV}}(N) = \frac{\frac{1}{N} \sum_{k=1}^N u(k)}{\frac{1}{N} \sum_{k=1}^N i(k)}$$

We will use MATLAB to simulate the behavior of these estimators. For each of the three estimators, carry out the following tasks (useful MATLAB commands are `help`, `plot`, `for`, `mean`, `std`).

- First, compute the result of the function $\hat{R}_*(N)$, for $N = 1, \dots, N_{\text{max}}$ using your personal measurements (student 1 or experiment 1). Do this for each estimator (* can be either SA, LS or EV). Plot the three curves in one plot. Do the estimators converge for $N \rightarrow \infty$?
- It is good practice to analyze the results of several experiments to cancel noise. Luckily, you get the datasets of all other students. Plot the function $\hat{R}_*(N)$, $N = 1, \dots, N_{\text{max}}$ for each estimator (* can be either SA, LS or EV). To see the stochastic variations, plot all these functions in one graph per estimator using `hold on`. Do you see any difference to the plot from task (a)?
- Compute the mean of $\hat{R}_*(N)$ over all experiments (all 200 students) and plot it for N from 1 to N_{max} .
- Plot a histogram containing all values of $\hat{R}_*(N_{\text{max}})$.

(4 points)

This sheet gives in total 10 points.